

Motorized Treadmill

XFIT ATLAS

User's Manual

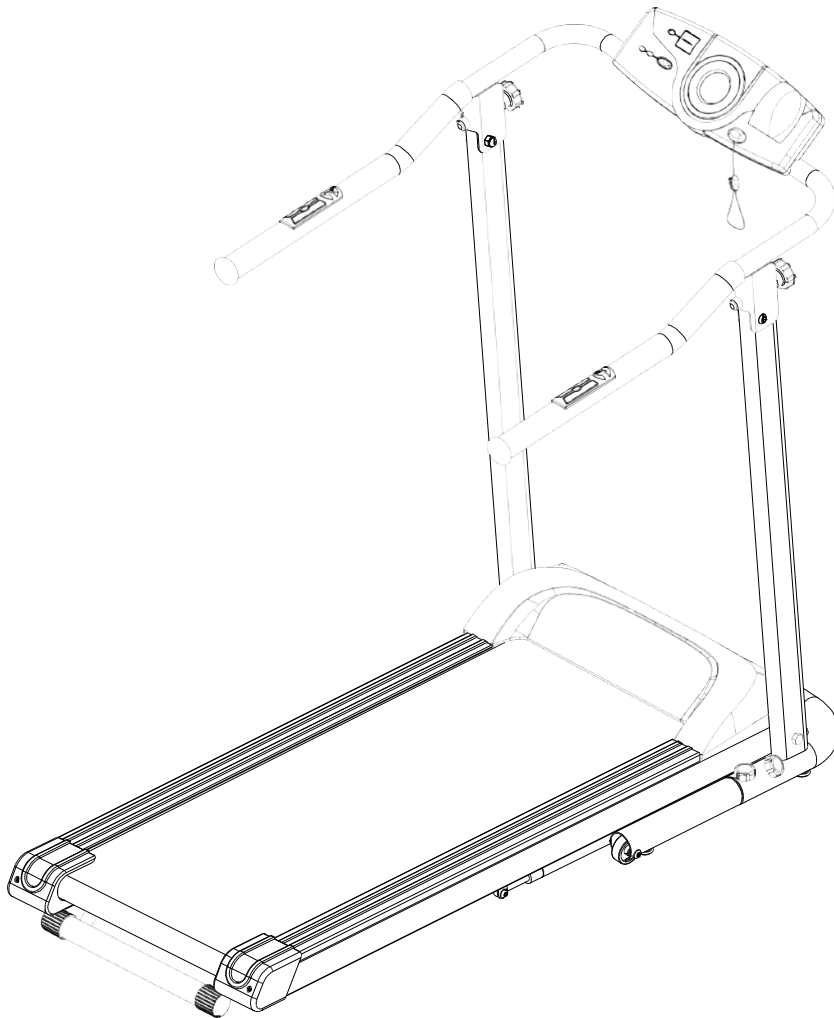

Read all instructions carefully before using this product. Retain this owner's manual for future reference. The specifications of this product may vary from this photo and are subject to change without prior notice.

TABLE OF CONTENTS

IMPORTANT SAFETY INSTRUCTIONS -----	3
PARTS LIST -----	5
ASSEMBLY COMPONENTS -----	7
TOOL -----	6
EXPLODED VIEW -----	8
ASSEMBLY INSTRUCTIONS -----	8
STORAGE -----	13
MOVING THE TREADMILL -----	14
OPERATING THE COMPUTER -----	15
EMERGENCY STOP -----	17
BELT ADJUSTMENT -----	18
LUBRICATION -----	19
INCLINE ADJUSTMENT -----	19
CARE, MAINTENANCE & TROUBLESHOOTING GUIDE -----	20
WARM UP AND COOL DOWN ROUTINE -----	22

IMPORTANT SAFETY INSTRUCTIONS

Basic precautions, including the following important safety instructions should always be followed when using this treadmill. Read all instructions before using this treadmill.

DANGER: To reduce the risk of electric shock, always unplug the treadmill from the electrical outlet immediately after using and before cleaning, assembling, or servicing the treadmill.

Failure to follow these instructions may lead to personal injury and cause damage to the treadmill.

WARNING: To reduce the risk of burns, fire, electric shock or injury to any persons, please read the following:

- Never leave the treadmill unattended while plugged in. Disconnect by turning off the master power switch and unplugging from wall outlet when not in use and before putting on or taking off parts.
- Use this appliance only for its intended use as described in this manual. Do not use attachments not recommended by the manufacturer.
- Never operate this treadmill if it has a damaged cord or plug, or if it is not working properly. If it has been dropped or damaged, or been exposed to water, return the appliance to a service center for examination and repair.
- Do not attempt any maintenance or adjustments other than those described in this manual. Should any problems arise, discontinue use and consult your local dealer.
- Never operate the appliance with the air openings blocked. Keep the air openings free of lint, hair, and other obstructions.
- Do not use the treadmill outdoors.
- Do not pull the treadmill by its power cord or use the cord as a handle.
- Keep children and pets away from the equipment while in use.
- Elderly or disabled users should only use this treadmill in the presence of an adult who can provide assistance if required.
- Do not operate where aerosol (spray) products are being used or where oxygen is being administered.
- Keep dry - do not operate in a wet or moist condition.
- The motor cover can become hot while the treadmill is in use. Do not place the treadmill on a blanket or other flammable surface as this can create a fire hazard.
- Keep electrical cord away from heated surfaces.
- Keep the treadmill on a solid, level surface with a minimum safety area clearance of two meters around the treadmill. Be sure the area around the treadmill remains clear of any obstructions during use.
- This treadmill is for domestic household use only.
- Only **one** person should use the treadmill at a time.
- Wear comfortable and suitable clothing when using the treadmill. Do not use the treadmill barefoot or in socks. Always wear appropriate, enclosed athletic footwear. Never wear loose or baggy clothing as it can become caught on the treadmill and create an entrapment hazard.
- Always hold on to the handlebar while using the treadmill.
- Always make sure the storage latch is in place when folding and moving the treadmill.
- Do not leave children who are under 12 years-old unsupervised near or on the treadmill.

- To disconnect, turn all controls to the off position, then remove plug from the wall outlet.
- This appliance is not intended for use by persons (including children) with reduced physical, sensory or mental capabilities, or lack of experience and knowledge, unless they have been given supervision or instruction concerning use of the appliance by a person responsible for their safety.
- Children should not be allowed to play on or near the treadmill at any time.
- CAUTION - RISK OF INJURY TO PERSONS - To avoid injury, use extreme caution when stepping onto or off of a moving treadmill belt. Carefully read this instruction manual before use.
- **Maximum Weight Capacity is 180 kgs.**
- This treadmill is designed for **WALKING** only.
- Pull out the Safety Tether Key for emergency stop.
- This unit must be plugged into a nominal 220-240 volt 50/60Hz outlet which has been grounded.
- Keep hands clear of all moving parts. Never place hands or feet under the treadmill while in use.
- Do not use the treadmill on a carpet that is greater than 1.3 cm in height.
- Before using the treadmill, check that the belt is aligned and centered on the running deck and all visible fasteners on the treadmill are sufficiently tightened and secure.
- Children shall not play with the appliance.
- Cleaning and user maintenance shall not be made by children without supervision.
- If the supply cord is damaged, it must be replaced by the manufacturer, its service agent or similarly qualified persons in order to avoid a hazard.
- Never operate this treadmill if it is in the folded position.
- Allow the running belt to fully stop and unplug the power cord from the wall outlet before folding up the treadmill.
- Always face towards the computer console and do not run backwards on the running belt.

WARNING: Before beginning any exercise program consult your physician. This is especially important for people who are over 35 years old or who have pre-existing health problems. Read all instructions before using any fitness equipment. Do not operate this exercise equipment without properly fitted guards, as the moving parts can present a risk of serious injury if exposed.

CAUTION: Read all instructions carefully before operating this product. Retain this Owner's Manual for future reference.

CAUTION! The company does not have no responsibility for causing damage due to misuse of the product and non-compliance with the instructions for use.

CAUTION! During exercise, heavy sweating can cause mechanical and electrical damage to the machine. Like any other liquid substance, sweat can cause damage mainly to the electrical parts of the machine (dial, cables, etc.). The best solution is to use a towel during exercise and wipe the machine after each use to avoid any unwanted damage.

Check and tighten the screws at regular intervals, as they may loosen due to vibrations. Damage that may be caused by a lack of maintenance is not covered by the warranty.

PARTS LIST

No.	Description	Qty	No.	Description	Qty
001	Main Frame	1	028	Computer Knob M6x45	2
002	Handlebar	1	029	Handlebar Knob M10x74	2
003	Incline Adjuster	1	030	Cross Recessed Truss Head Bolt M10x45	2
004	Safety Tube A (30x40x480mm)	1	031	Nut Cap M10	2
005	Safety Tube B (20x20xT1.2x350mm)	1	032	Nylon Nut M10	2
006	Gas Spring	1	033	Handlebar Foam Grip Ø30xT3.0x480mm	2
007	Hexagon Head Bolt M12x90	2	034	Handlebar End Cap Ø50x37.5	2
008	Stabilizer Knob M8x20	4	035A	Function Buttons and Hand Pulse Sensor with Wire (L=650 mm)	1
009	Adjustable Leveler M8x20	5	035B	Speed Buttons and Hand Pulse Sensor with Wire (L=650 mm)	1
010	Transport Wheel Ø50x22	2	036	Cross Recessed Oval Head Tapping Screw 4x20	4
011	Spacer Ø12xØ8.5x15	4	037	Power Cord (L=1700 mm)	1
012	Hexagon Socket Oval Head Bolt M8x55	2	038	Socket	1
013	Nut Cap M8	2	039	Power Switch	1
014	Square End Cap (30x30x12mm)	1	040	Fuse Box	1
015	Hexagon Socket Oval Head Bolt M8x40	1	041	Wire for Fuse Box (L=100 mm)	1
016	Washer Ø16xØ8	1	042	Wire for Power Control Board (L=180 mm)	1
017	Square Bushing (30x30x28mm)	1	043	Power Control Board	1
018	Square Bushing (26x26x50mm)	1	044	Power Control Board Plastic Plate	1
019	Hexagon Socket Oval Head Bolt M8x35	1	045	Cross Recessed Oval Head Tapping Screw 3x12	4
020	Nylon Nut M8	2	046	Cross Recessed Oval Head Bolt M5x15	4
021	Square End Cap (20x20x12mm)	1	047	Nylon Nut M5	4
022	Hexagon Socket Oval Head Bolt M8x20	1	048	Ring for Power Cable Ø16xØ13xT28	2
023	Hexagon Socket Oval Head Bolt M8x30	1	049	Earth Lead (L=400 mm)	1
024	Wire Grommet Ø16	3	050	Spring Washer M4	3
025	Extension Control Cable (L=2100 mm)	1	051	Motor	1
026	Computer	1	052	Optical Coupler	1
027	Safety Tether Key	1	053	Hexagon Head Bolt M8x20	4

PARTS LIST

No.	Description	Qty	No.	Description	Qty
054	Spring Washer M8	4	072	Cross Recessed Truss Head Screw M5x10	13
055	Flange Nut M8	4	073	Side Rail 80x12x1090mm	2
056	Buffer 55x35x8.5mm	6	074	Cross Recessed Oval Head Tapping Screw 3x8	8
057	Support Board 50x12xT4x556mm	1	075	Rear Left End Cover	1
058	Round End Cap Ø25x15	2	076	Rear Right End Cover	1
059	Incline Adjuster End Cap Ø45x40	2	077	Spring Knob	1
060	Cross Recessed Truss Head Bolt M10x40	2	078	Short Knob	1
061	Spacer Ø14xØ10.2x19	2	079	Washer Ø21xØ10xT1.5	2
062	Running Deck 945x560xT20	1	080	Stabilizer	1
063	Cross Recessed Countersunk Head Bolt M6x40	8	081	Left Stabilizer Tube Ø50xT1.5x435mm	1
064	Flange Nut M6	8	082	Right Stabilizer Tube Ø50xT1.5x435mm	1
065	Front Roller Ø120xØ42xØ15x627	1	083	Rectangular End Cap (□50x25)	2
066	Hexagon Socket Round Head Cap Bolt M8x55	3	084	Plastic Washer Ø7xØ5x10	4
067	Cross Recessed Truss Head Bolt M6x20	1	085	Washer Ø22xØ8	4
068	Belt 180J6	1	086	Cross Recessed Truss Head Bolt M3x15	2
069	Running Belt	1	087	Cross Recessed Truss Head Bolt M5x10	2
070	Rear Roller Ø42xØ15x620	1	088	Optical Coupler Bracket	1
071	Motor Cover	1	089	Rubber Washer Ø22xØ8.5x3.5T	4

ASSEMBLY COMPONENTS

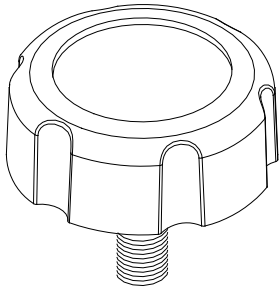

(8) Stabilizer Knob
4 PCS

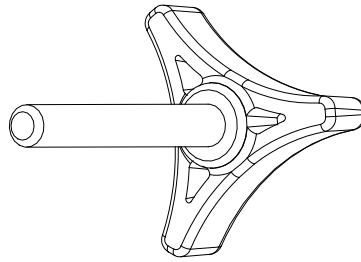

(28) Computer Knob
2 PCS

TOOL

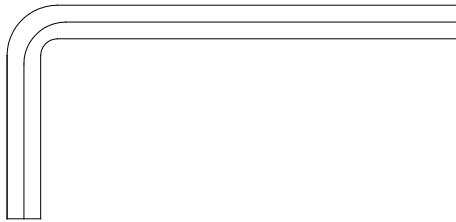

Allen Wrench
1 PC

ASSEMBLY INSTRUCTIONS

Note: Assembly requires 2 people.

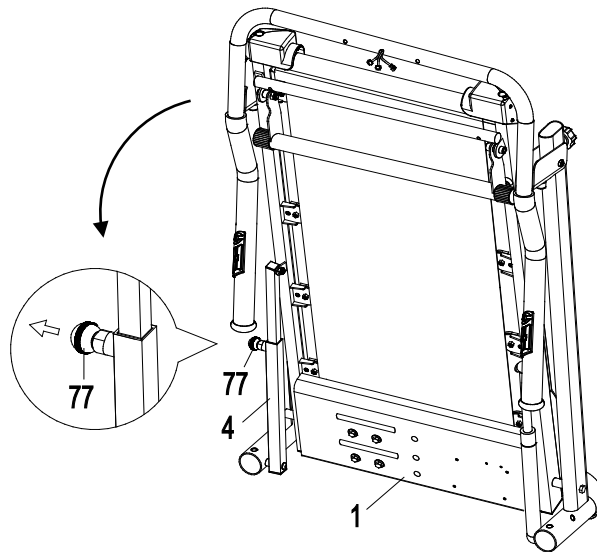

Step 1

Place the treadmill in the upright position on a level surface. Place one hand on the rear end of Main Frame (1) and use your other hand to pull out the Spring Knob (77). Lower the Main Frame (1) down from the rear of treadmill until the Spring Knob (77) "pops" into the locked position and the Main Frame (1) is flat with the ground.

TO PREVENT INJURY PLEASE MAKE SURE YOU HAVE A FIRM HOLD WHEN SETTING DOWN THE DECK.

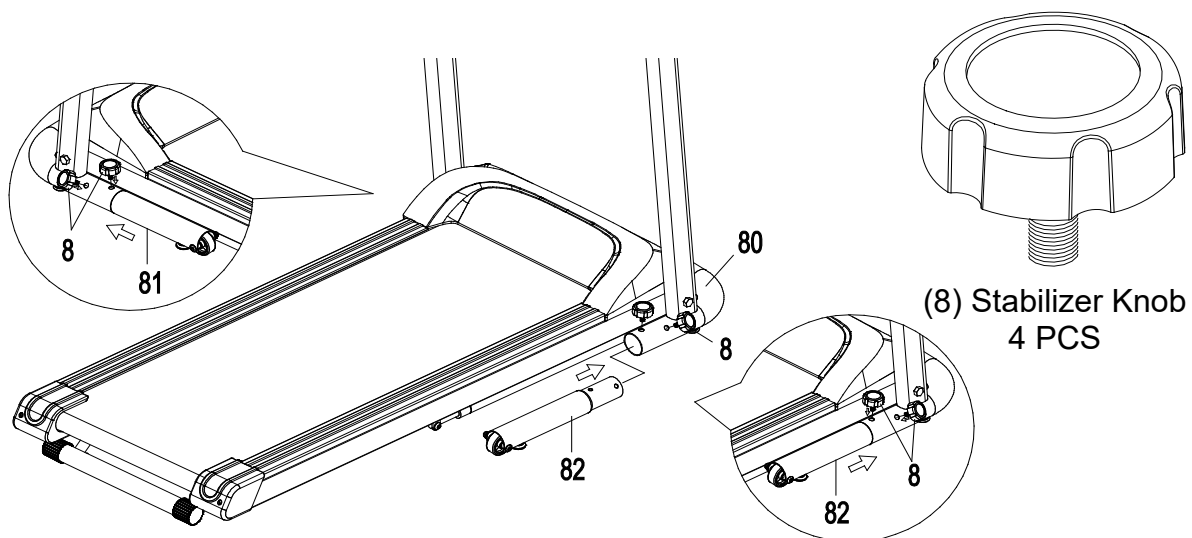

Step 2

Using two Stabilizer Knobs (8) to install the Right Stabilizer Tube (82) into the Stabilizer (80), and thoroughly tighten the Stabilizer Knobs (8). Repeat the step above on the LEFT side to install the Left Stabilizer Tube (81).

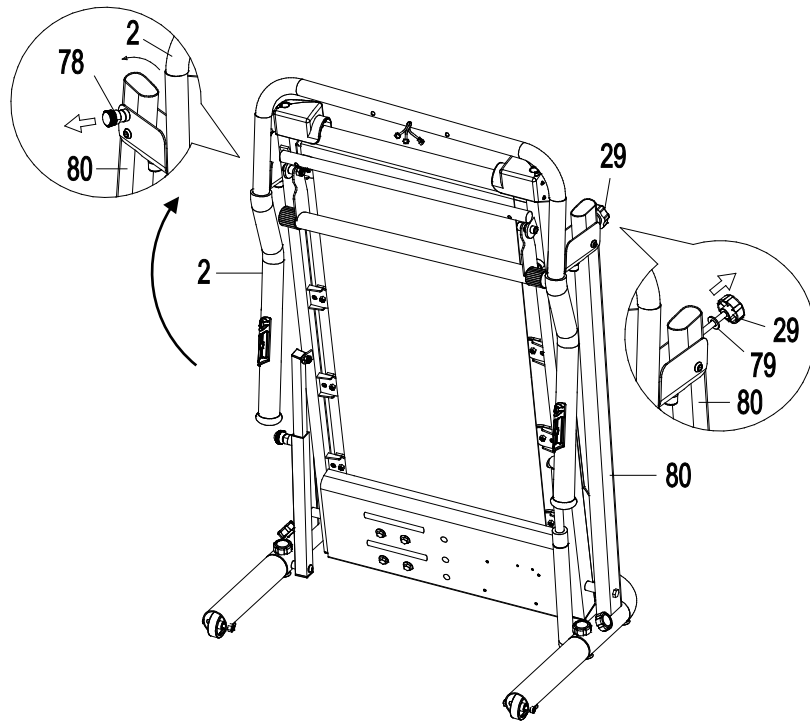

Step 3

Pull both Handlebar Knobs (29) and Washers (79) out. Pull the Short Knob (78) and then lift the Handlebar (2) all the way up.

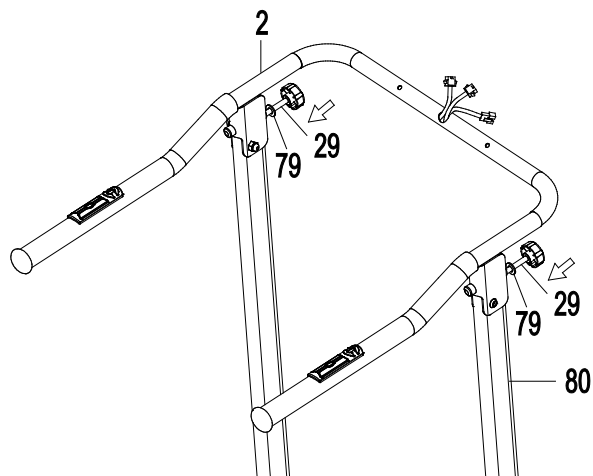

Step 4

Release the Short Knob (78) and ensure that it “pops” into the locked position. Secure the Handlebar (2) to the Stabilizer (80) with two Handlebar Knobs (29) and two Washers (79).

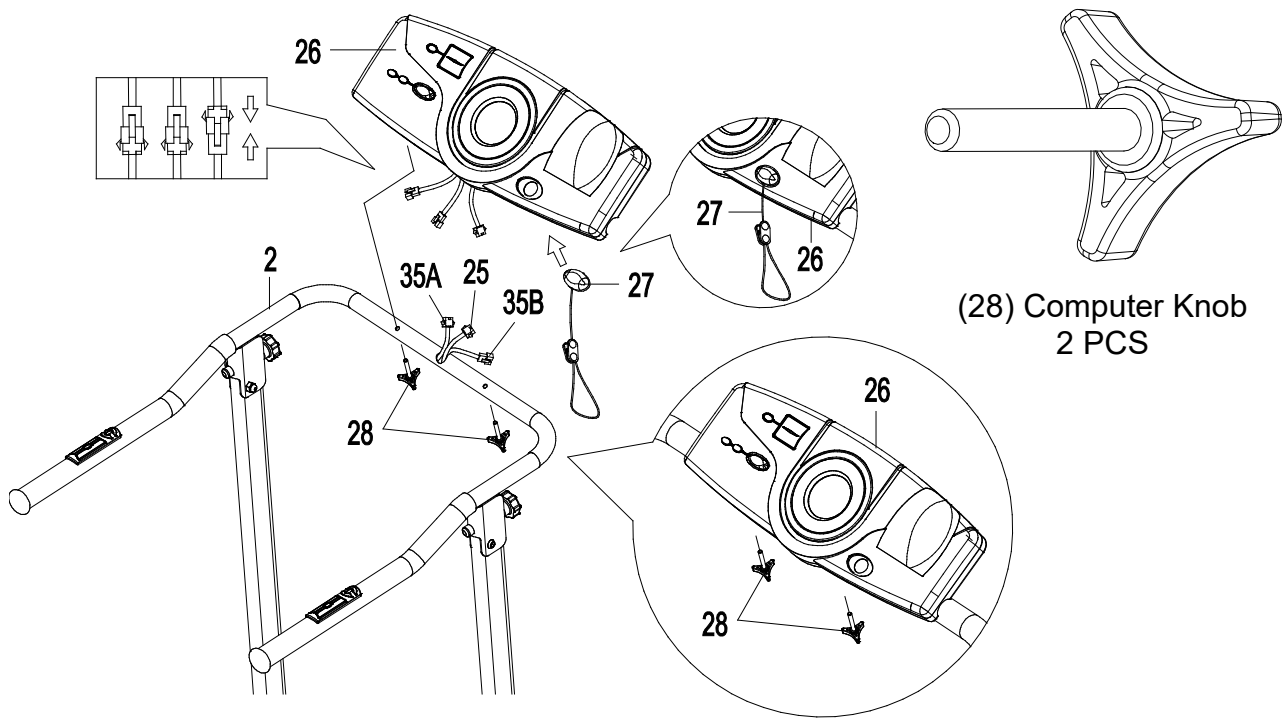

Step 5

It is recommended to have a second person assist with this step. One person should hold the Computer (26) in place while the other person to connect the wires.

Connect the Function Buttons and Hand Pulse Sensor Wire (35A), Speed Buttons and Hand Pulse Sensor Wire (35B), and Extension Control Cable (25) from the Handlebar (2) to the wires that come from the Computer (26).

Attach the Computer (26) onto the Handlebar (2) with two Computer Knobs (28). Be sure to tuck the excess wires into the frame.

Place the Safety Tether Key (27) onto the computer (26).

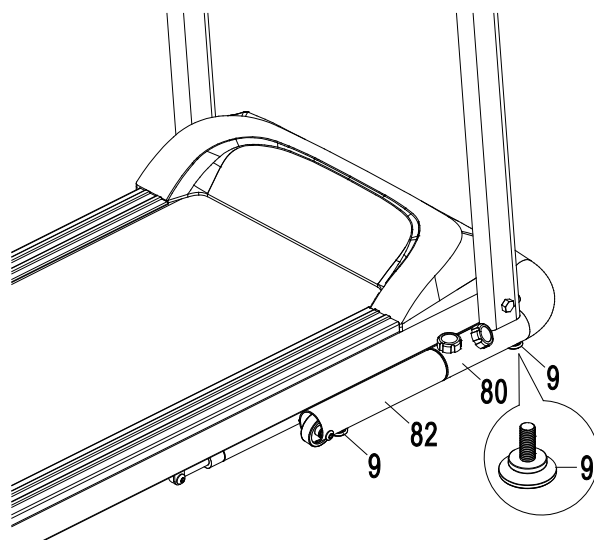

Step 6

There are five Adjustable Levelers (9) on the bottom of Left/Right Stabilizer Tubes (81, 82) and Stabilizer (80). Turn the Adjustable Leveler (9) as needed to level the treadmill.

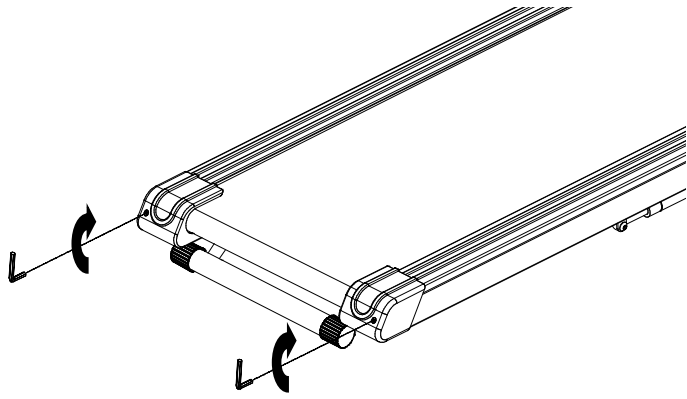

Tool:



Allen Wrench

Step 7

The running belt has been adjusted to the running deck at the factory before it was shipped. At times the running belt may get slippery during shipment. After the treadmill is completely assembled, use the Allen Wrench provided to turn the both left and right rear roller adjustment bolts 1/4 turn clockwise before using the treadmill.

STORAGE

A

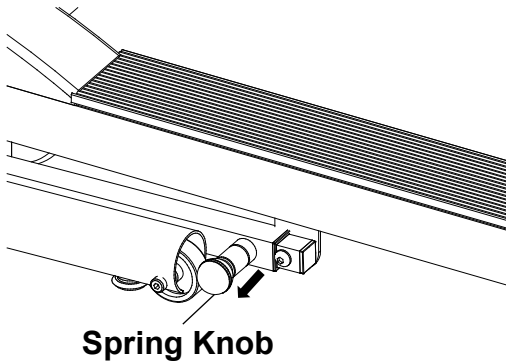

B

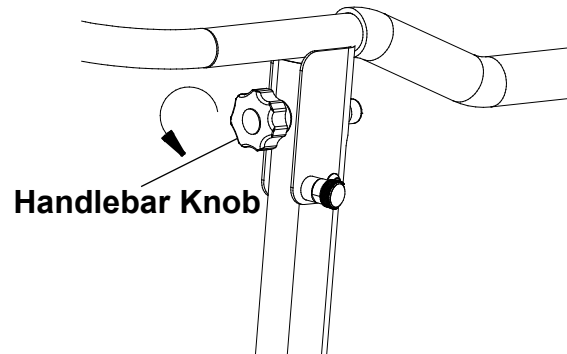

C

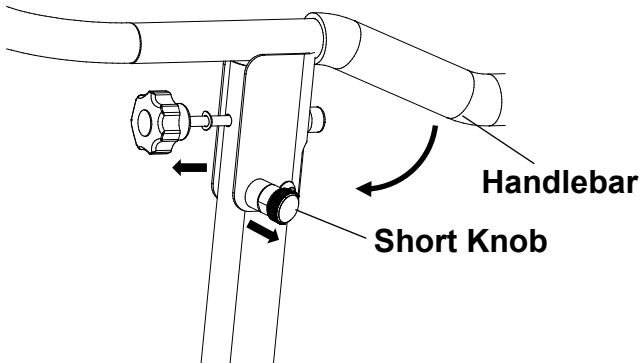

D

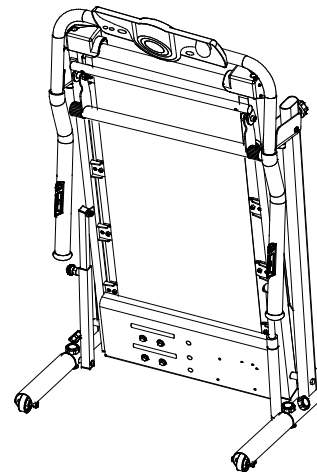

FOLDING THE TREADMILL

For your convenience, the treadmill can be folded up and placed in a storage area. To fold the treadmill place one hand on the rear end of main frame and use your other hand to pull out the Spring Knob, then lift the main frame up until the Spring Knob "pops" down into the locked position as shown in figure A. Release both Handlebar Knobs as shown in figure B. Pull out the Short Knob and then push the Handlebar all the way down. Insert both Handlebar Knobs back to the Stabilizer as shown in figure C. The figure D shows the treadmill in the folded position. Now the treadmill is ready to be stored.

IMPORTANT: TO PREVENT INJURY PLEASE MAKE SURE YOU HAVE A FIRM HOLD WHEN LIFTING UP OR SETTING DOWN THE DECK.

MOVING THE TREADMILL

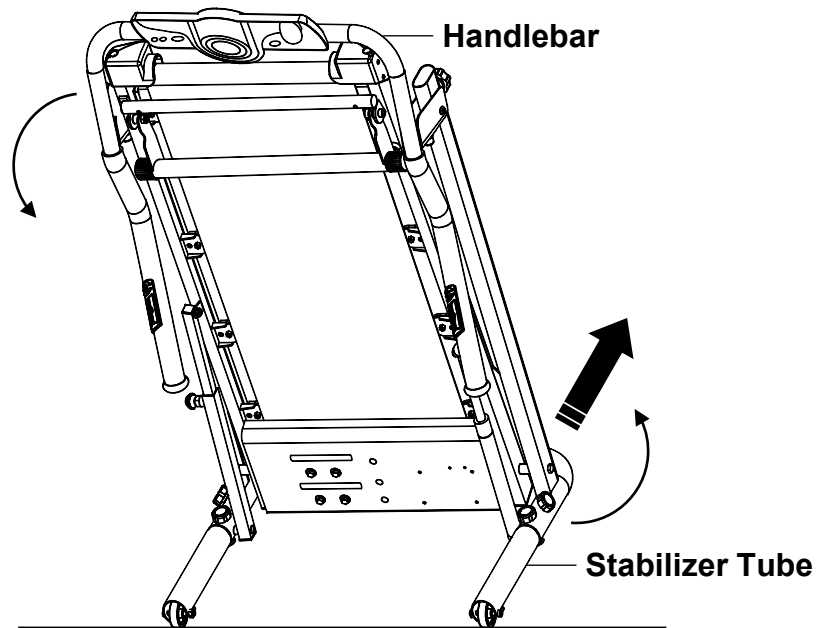

The unit can be carefully tilted onto its transport wheels for easy moving and storage. With the treadmill in the folded locked position, firmly grasp the Handlebar with both hands and place one foot on the Stabilizer Tube. Next, carefully tilt the treadmill back until it rolls freely on the transport wheels.

To set the treadmill down, place one foot on the Stabilizer Tube and carefully lower treadmill onto base in the folded position.

CAUTION: The treadmill is heavy, it is suggested you always use the aid of a second person when moving the treadmill. Do not attempt to move the treadmill while it is in the unfolded position.

OPERATING THE COMPUTER

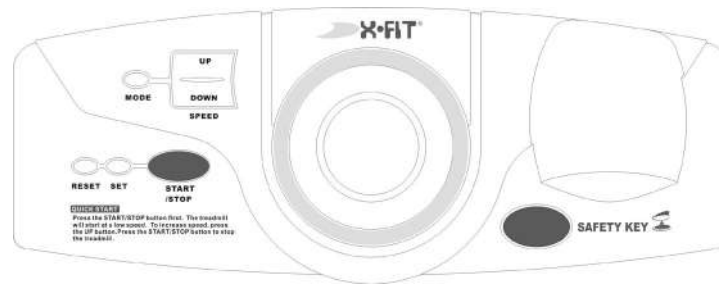

Flip the Master Power Switch that is located at the front of the treadmill to the ON position. Before beginning a workout session ensure that the magnetic end of the Safety Tether Key is properly placed onto the Computer Console and the Safety Clip is securely attached to an article of your clothing.

NOTE: Always stand on the side rails when you start the treadmill, never start the treadmill while you are standing on the running belt.

QUICK START:

Press the START/STOP button to start exercise. The treadmill will start moving at a speed of 0.6 KPH. The split window of TIME will display in your elapsed workout TIME. The split window of DISTANCE will display your cumulative DISTANCE. The split window of CALORIES will display your total CALORIES burned during your workout. The split window of PULSE will display your current heart rate 4 - 5 seconds after you grip the handlebar sensors with both your hands during exercise. Please hold on to both handlebar sensors for a more precise reading. You may press the SPEED UP or SPEED DOWN button on the computer console to increase or decrease the walking speed during exercise. The treadmill's speed range is from 0.6 KPH to 8.0 KPH. The split window of SPEED will display your current speed. During training, you may press the START/STOP button to stop the treadmill running at any time, press the START/STOP button to start the treadmill running again. You may pull out the safety tether key to stop the treadmill running.

COMPUTER BUTTON FUNCTIONS

START/STOP: Press the START/STOP button to start or stop the treadmill.

MODE: Press the MODE button to select each function (TIME, DISTANCE, or CALORIES) for set up a workout goal value.

SET: Press the SET button to set goal values of TIME, DISTANCE, or CALORIES.

RESET: Press the RESET button to clear data values of TIME, DISTANCE, or CALORIES to zero.

Press and hold the RESET button for 2 seconds, the computer will be restarted.

SPEED UP: Press the SPEED UP button to increase speed.

SPEED DOWN: Press the SPEED DOWN button to decrease speed.

COMPUTER FUNCTIONS

TIME: Displays your elapsed workout time in minutes and seconds, or counts down from your target workout time if you have selected this training mode. TIME can be set between 1:00 to 99:00 minutes.

SPEED: Displays the current speed from the minimum 0.6 KPH to the maximum 8 KPH.

DISTANCE: Displays the total distance travelled during your workout, or counts down from your target distance if you have selected this training mode. DISTANCE can be set between 0.10 to 99.90 kilometers.

CALORIES: Displays the total calories burned during your workout, or counts down from your target calories if you have selected this training mode. CALORIES can be set between 10 to 9990 calories burned.

PULSE: Displays your current heart rate in beats per minute (BPM). To activate, grip the hand pulse sensors during exercise and the pulse will display after 4-5 seconds. For a more accurate reading, grip pulse sensors with both hands.

NOTE: The display console will automatically enter sleep mode when no activity is detected after 10 minutes. To reactivate the display, press the START/STOP button.

CAUTION! The heart rate sensor and calorie counter are not medical devices. Several factors can affect the accuracy of the indications. The heart rate sensor is only intended as an aid during exercise to monitor your heart rate in general.

CAUTION! During exercise, heavy sweating can cause mechanical and electrical damage to the machine. Like any other liquid substance, sweat can cause damage mainly to the electrical parts of the machine (dial, cables, etc.). The best solution is to use a towel during exercise and wipe the machine after each use to avoid any unwanted damage.

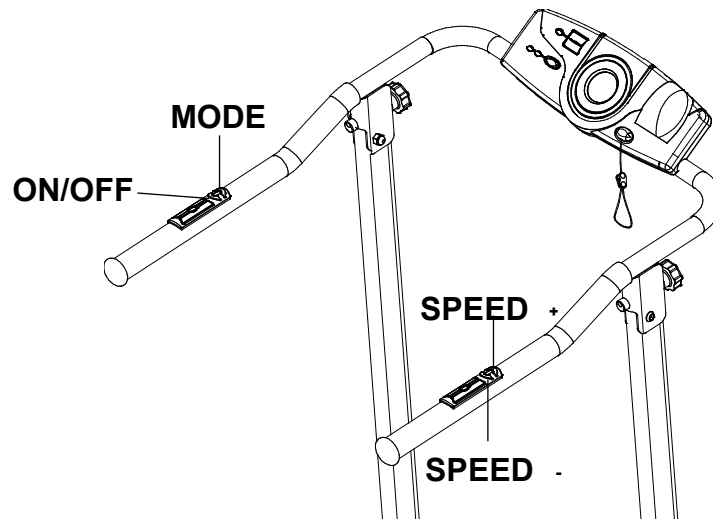

MODE: Press the MODE button on the Left Handrail to select each function (TIME, DISTANCE, CALORIES, or PULSE) for set up a workout goal value.

ON/OFF: Press the ON/OFF button Located on the Left Handrail to start or stop the treadmill.

SPEED + : Press the SPEED + button on the Right Handrail to increase speed.

SPEED - : Press the SPEED - button on the Right Handrail to decrease speed.

EMERGENCY STOP

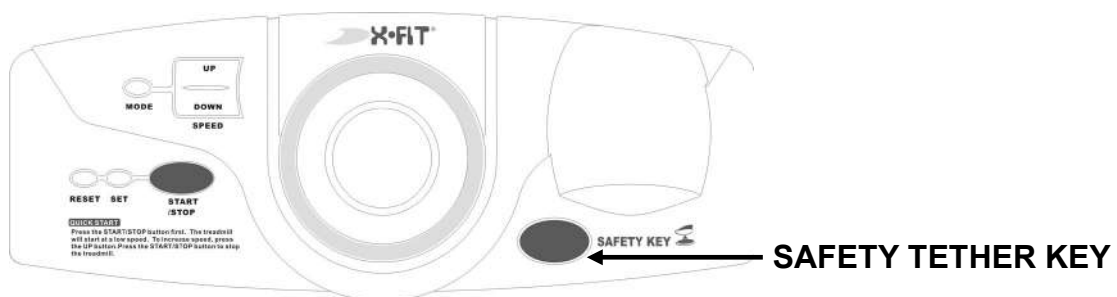

Before beginning a workout session ensure that the Safety Tether Key is properly placed onto the Computer Console and the Safety Clip is securely attached to an article of your clothing. If you fall the clip will pull out the **SAFETY TETHER KEY** from the Computer Console and the running belt will stop immediately for emergency stop, helping to prevent injury.

Replaced the Safety Tether Key onto the Computer Console. Press the START/STOP button to begin exercise again.

IMPORTANT: The SAFETY KEY has a magnet which is connected to the console. At the other end there is a clip that must be placed on your clothes. The treadmill only works with the safety key on the console.

BELT ADJUSTMENT

The running belt is pre-adjusted to the running deck at the factory, but after prolonged use it can stretch and require readjustment. To adjust the belt, turn on the main power switch of the treadmill and let the belt run at a speed of 2-4 KPH. Use the Allen Wrench provided to turn the rear roller adjustment bolts in order to centre the belt. If the running belt is shifting to the left, turn the left adjustment bolt 1/4 turn clockwise, and the running belt should start to correct itself.

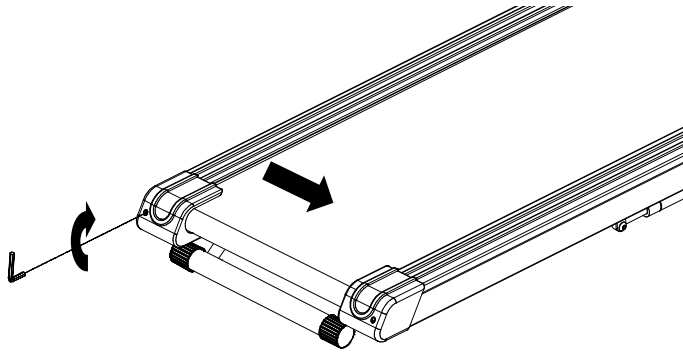

Tool:

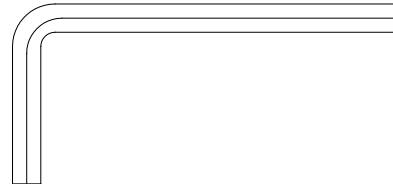

Allen Wrench

If the running belt is shifting to the right, then turn the right adjustment bolt 1/4 turn clockwise, and the belt should start to correct itself. Keep turning the adjustment bolts until the running belt is properly centered.

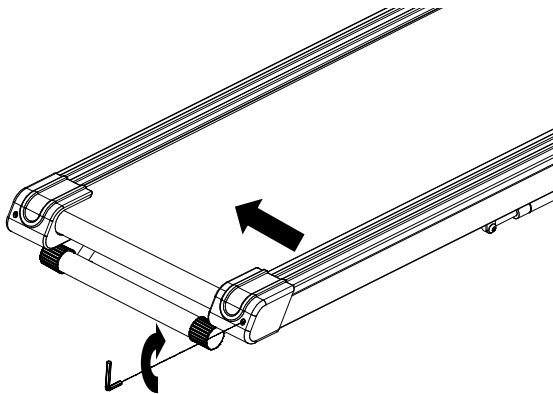

Tool:



Allen Wrench

If the running belt is slipping during use, turn off and unplug the treadmill. Using the Allen Wrench provided, turn both left and right rear roller adjustment bolts 1/4 turn clockwise, then turn the main power switch back on and run the treadmill at a speed of 2-4 KPH. Run on to the running belt to determine if the belt is still slipping. Repeat this procedure until the belt no longer slips.

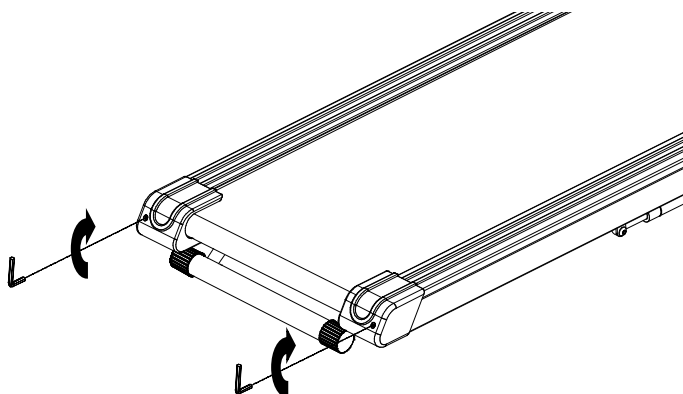

Tool:



Allen Wrench

LUBRICATION

Lubricating under the running belt will ensure superior performance and extend its life expectancy. After the first 25 hours of use (or 2-3 months) apply some lubricant, and repeat for every following 50 hours of use (or 5-8 months).

How to check running belt for proper lubrication

Lift one side of the running belt and feel the top surface of the running deck.

If the surface is slick to the touch, then no further lubrication is required.

If the surface is dry to the touch, apply some lubricant.

How to apply lubricant

Lift one side of running belt.

Pour some lubricant under the **centre** of the running belt on the top surface of the **running deck**.

Run on the treadmill at a slow speed for 3 to 5 minutes to evenly distribute lubricant.

NOTE: DO NOT over lubricate running deck. Any excess lubricant that comes out should be wiped off.

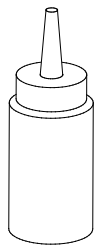

Lubricant
1 PC

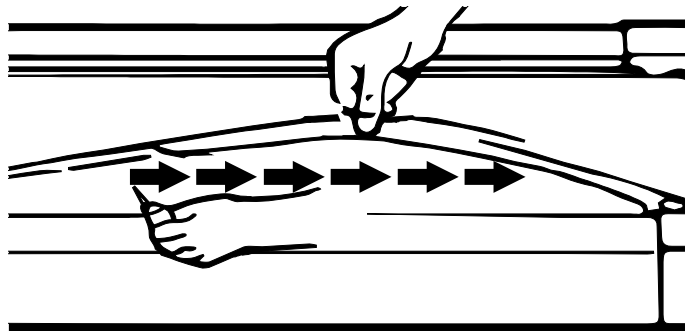

WARNING: The contact between the wooden surface of the treadmill and the treadmill plays an important role in the operation and life of the treadmill. We recommend that you keep the treadmill clean and lubricate it frequently, following the instructions for use. Incomplete lubrication causes damage to the belt and electrical parts of the treadmill.

INCLINE ADJUSTMENT

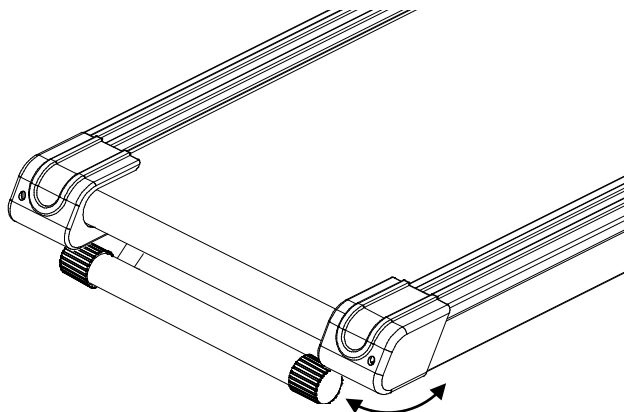

Place one hand on the rear end of main frame. Lift the main frame up then adjust the Incline Adjuster to the desired position.

CARE, MAINTENANCE & TROUBLESHOOTING GUIDE

WARNING: To prevent electrical shock, please turn off and unplug the treadmill before cleaning or performing routine maintenance.

WARNING: Always check the wear and tear components like safety tubes and running belt to prevent injury.

CLEANING

After each exercise, ensure that the unit is wiped down and any sweat is removed from the unit.

The treadmill can be cleaned with a soft cloth and mild detergent. Do not use abrasives or solvents. Be careful not to get excessive moisture on the display panel as this might damage the unit and create an electrical hazard.

Please keep the treadmill, especially the console, out of direct sunlight to prevent damage to the screen.

STORAGE

Store the treadmill in a clean and dry indoor environment. Never leave or use the unit outdoors. Ensure the master power switch is off and the power cord is un-plugged from wall outlet.

CAUTION! The use of a protective carpet (plastic carpet or thin carpet) under the fitness machine is considered essential for its proper use, avoidance of vibrations and protection of the floor. The company does not bear any responsibility for causing damage due to misuse of the product and non-compliance with the instructions for use.

TROUBLESHOOTING GUIDE

Problem	Potential Causes	Corrections
Treadmill will not start.	<ol style="list-style-type: none"> 1. Treadmill not plugged in. 2. Safety Tether Key not correctly installed. 3. Circuit breaker in the house has been tripped. 4. Treadmill circuit breaker has been tripped. 	<ol style="list-style-type: none"> 1. Plug the power cord into a wall outlet. 2. Reinstall the Safety Tether Key. 3. Reset the circuit breaker, or call an electrician to replace the circuit breaker. 4. Wait 5 minutes and then try to restart the treadmill.
Belt slips.	Belt not tight enough.	Adjust belt tension.
Belt hesitates when stepped on.	<ol style="list-style-type: none"> 1. Not enough lubrication applied onto the running deck. 2. Belt is too tight. 	<ol style="list-style-type: none"> 1. Apply lubricant. 2. Adjust belt tension.
Belt is not centred.	Running belt tension not even across the rear roller.	Centre the belt.

WARM UP AND COOL DOWN ROUTINE

The **WARM-UP** is an important part of any workout. The purpose of warming up is to prepare your body for exercise and to minimize injuries. Warm up for two to five minutes before aerobic exercising. It should begin every session to prepare your body for more strenuous exercise by heating up and stretching your muscles, increasing your circulation and pulse rate, and delivering more oxygen to your muscles.

COOL DOWN at the end of your workout, repeat these exercises to reduce soreness in tired muscles. The purpose of cooling down is to return the body to its resting state at the end of each exercise session. A proper cool-down slowly lowers your heart rate and allows blood to return to the heart.

HEAD ROLLS

Rotate your head to the right for one count, you should feel a stretching sensation up the left side of your neck. Then rotate your head back for one count, stretching your chin to the ceiling and letting your mouth open. Rotate your head to the left for one count, then drop your head to your chest for one count.

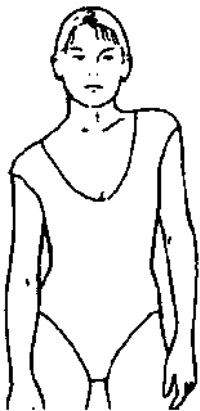

SHOULDER LIFTS

Lift your right shoulder toward your ear for one count. Then lift your left shoulder up for one count as you lower your right shoulder.

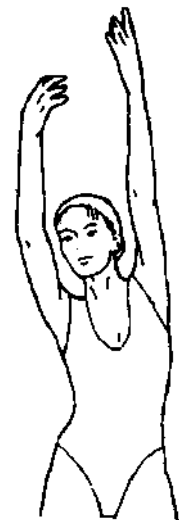

SIDE STRETCHES

Open your arms to the side and lift them until they are over your head. Reach your right arm as far toward the ceiling as you can for one count. Repeat this action with your left arm.



QUADRICEPS STRETCH

With one hand against a wall for balance, reach behind you and pull your right foot up. Bring your heel as close to your buttocks as possible. Hold for 15 counts and repeat with left foot.

INNER THIGH STRETCH

Sit with the soles of your feet together and your knees pointing outward. Pull your feet as close to your groin as possible. Gently push your knees toward the floor. Hold for 15 counts.

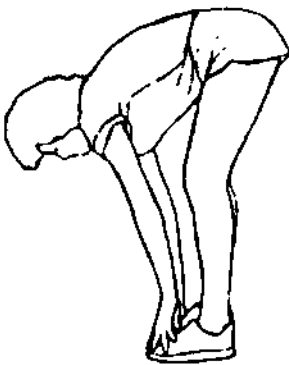

TOE TOUCHES

Slowly bend forward from your waist, letting your back and shoulders relax as you stretch toward your toes. Reach as far as you can and hold for 15 counts.

HAMSTRING STRETCHES

Extend your right leg. Rest the sole of your left foot against your right inner thigh. Stretch toward your toe as far as possible. Hold for 15 counts. Relax and then repeat with left leg.

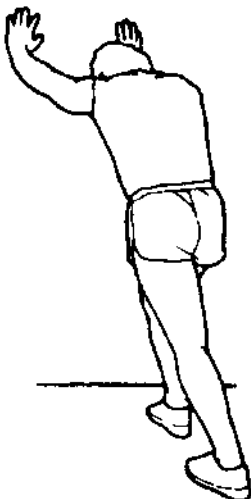
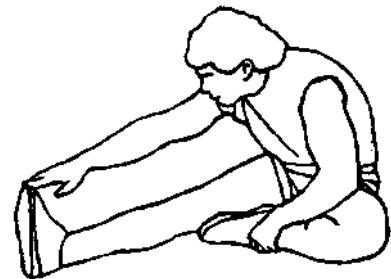

CALF/ACHILLES STRETCH

Lean against a wall with your right leg in front of the left and your arms forward. Keep your left leg straight and the right foot on the floor; then bend the right leg and lean forward by moving your hips toward the wall. Hold, then repeat on the other side for 15 counts.



TERMS OF WARRANTY

- Warranty period is 2 years for mechanical, electrical / electronic parts and 5 years for the metal frame.
- X-TREME STORES S.A. undertakes to repair the machine free of charge in the event of damage due solely to a manufacturing fault. The warranty covers the cost of the spare parts. Replacement of spare parts or not is up to the company technicians. The customer is responsible for the control and adjustment of the machine.
- This warranty note is only valid if it is accompanied by legal proof of purchase (invoice or retail receipt). The warranty period is not extended for any reason and the transfer of it to a third party is excluded.
- Any damage is repaired as soon as possible and any claim for damages due to lack of spare parts and delay in repairing the damage is excluded. The costs of transporting the machine to or from the dealership will be borne by the customer after 6 months of purchase.
- The warranty conditions are set by the manufacturers of machinery and are governed by European regulations.
- Upon expiry of the warranty, any replacement part is covered by a 6-month warranty.

THE WARRANTY SHALL NOT APPLY:

- When the machine is used for any purpose other than home use (gyms, clubs, institutes, hotels, studios, etc.).
- When the fault is the result of misuse, alterations, poor connection, poor maintenance, voltage fluctuations in the PPC network.
- Components damaged by user fault such as broken plastic parts, damaged belt with improper adjustment, incorrect or incomplete lubrication, damage when moving the machine.
- Components such as side pads and cushions are considered consumables and are covered by a 6-month warranty.
- When the machine is opened or repaired by third parties.
- When the damage is caused by the buyer's negligence & the instructions for use have not been followed.
- When the machine is outdoors or exposed to sun or dust. (Dust and lint on the inside of the machine (motor roller) cause serious damage. Keep the machine clean!).
- When electronic components (console) are damaged by intense sweating or other liquid that has come into contact with or penetrated inside them.



34 koupi Avenue, Koropi
P.C.:19441 - P.O. Box 6201
Tel.: 210 66 20 921 -2 - **Fax:** 210 66 20 923
E-mail: info@xtr.gr • [f/xtrstores](https://www.facebook.com/xtrstores) • [/xtr.gr](https://www.instagram.com/xtr.gr)

Tel. for all of Greece:
801.11.15.100

www.xtr.gr